

Technical rider and Stage plot

For any information, please contact:

Mohanad Abu Hamdieh

Mobile: +972 599 533309

E-mail: mras66@hotmail.com

STAGING SPECIFICATIONS (see plan)

- STAGE Minimum Dimensions
 - Width : 10 m.
 - Depth : 7 m.
- Chairs on stage five (5),
- Note stands with lights on stage (5).

See "stage plot" for positions

- Please provide us with a big table (standard size) or two small size tables for merchandise.

SOUND REINFORCEMENT

- Professional quality system, E.g.: Martin-Audio / Mayer sound / Lacoustic Line array / D&B, with all Subs needed, near field and Front fills and delay tours if needed.
- The size of the PA system should be able to deliver 106 dB SPL (A), high quality and distortion-free sound pressure to audience capacity with definition, clarity and uniformity, across venue.
- **Venue – FOH eng., Stage Monitor eng. and assistants** should be available throughout the rehearsals and concert days.
- House mix position shall be at a distance of 10-20 meters from the stage, aligned to the stage centre.
- Dalouna FOH eng. shall have access to system processors to correct linearity where needed.
- Dalouna FOH eng. shall have access to venue and stage from 8:00 AM till end of rehearsals and concert.

HOUSE MAINS:

- **FOH Digital mixing desk console, 48 channels / 16 out stage box**

- Preferred console, Midas Pro X / 9 / 6 / 3 / 2 / 2C.
- Sound craft VII / VI4 / VI6.
- Allen & Heath I Live digital 144 / T112

If Analogue mixer 48 channels:

- Midas heritage / Legend
- Sound craft MH4 / MH3 / Series five.
- Allen & Heath ML 5000 / 4000

Out board

1 x GEQ Dual 31 Band at masters (left, right) Bss / Klark Teknik dn360 / XTA.

5 x GEQ 31 Band at Aux send (1 – 7) Bss / Klark Teknik dn360 / XTA.

10 x compressors Bss / Klark Teknik / XTA.

2 x SPX 2000 / SPX 990 / lexicon pcm 70/80/81/91

1 x TC D-two delay.

Stage monitor system:

A dedicated stage monitor mix system is highly recommended with well experienced monitor eng. to operate if possible. Otherwise stage monitors will be mixed from FOH by Dalouna eng.

All monitors shall be **(Identical)**

5 x stage monitors 15” / 12”

SPECIFIC GEARS:

- All clip on microphones DPA / ATM are a must.
- Provide intercom between FOH desk and backstage.
- Black box 60-80 cm. height for Double bass monitor.
- Microphones: see the patch list, stands.
- Digital recording machine / CD-R / computer with sound card to record the concert.

Back line:

STAGE LIGHT

- Use warm color gels (see DVD)
- If moving heads to be used (EXTREM SOFT MOVEMENTS ONLY)
- Please provide enough lighting for musicians and singers on stage to see scores properly

Microphone Patch List

All lines, microphones, stands shall be ready, tested and in best condition

CH.#	Inst. Inputs	Mice.	Insert	Mix	Stands
1	Perc. 1	Beta 57	Comp.	Mix 2	Short
2	Buzoq	ATM 35 / Pro 35		Mix 5	Short
3	LOUD	KM184 / Sm81		Mix 6	Clip on

4	LOUD	We carry		Mix 6	Clip on
5	Acc HI	Beta 87 / Sm57	Comp.	Mix 7	Short
6	Acc Low	Beta 87 / Sm57	Comp.	Mix 7	Short
7	VOX Buzoq	Beta 58 / Sm58	Comp.	Mix 5	Medium
8	VOX oud	Beta 58 / Sm58	Comp.	Mix 6	Medium
9	Solo VOX	Beta 58 / Sm58	Comp.	Mix 1	Long
10	Spare				
11	TB	Sm58		All Mixes	At control

22-Jan-16

Stage Plot

Daluona Musical group

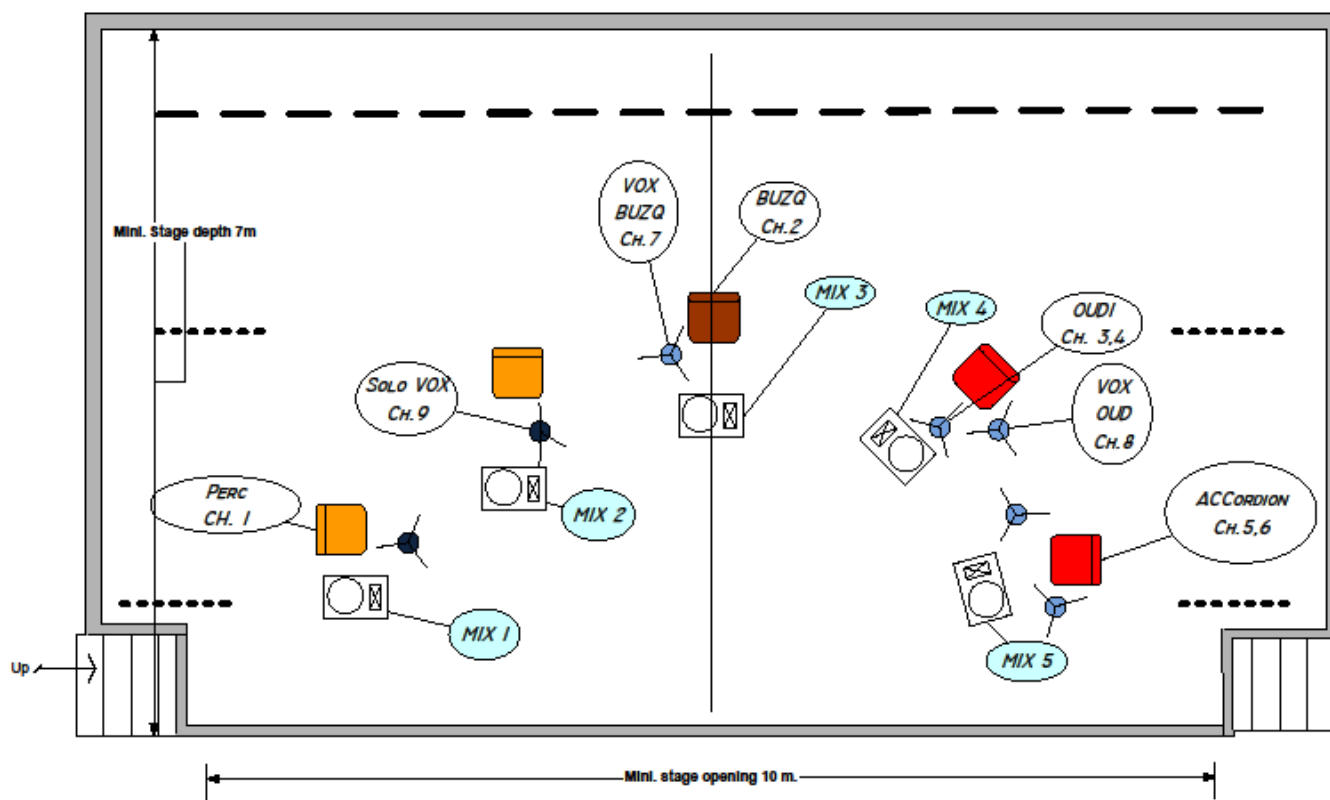

Mohamad AH. Mobile: +972 599 533309

Email: mras66@hotmail.com